



STANDARD FEATURES AND OPTIONS SPECIFICATIONS

STANDARD FEATURES - CHASSIS	SPECIFICATIONS	MS 100	MS 250	MS 500
Polaris Ranger 6 x 6 Chassis - Modified	On Demand Six Wheel Drive 40 HP, Up to 40 MPH	■	■	■
Mirrors	Left / Right / Rear View	■	■	■
Headlights	Two (2) 50 Watt Quartz/Halogen Bulbs	■	■	■
Dome Light	One (1) 14" Fluorescent Light Fixture	■	■	■
Tail Lights	Two (2) Red Taillight Bulbs Mounted in Tail Panel	■	■	■
STANDARD FEATURES - PATIENT COMPARTMENT				
All Aluminum Patient Compartment	.125" Aluminum, Tread Plate Floor and Extruded Corners	■	■	■
Painted Interior - Zolatone Finish	Interior Ceiling, Front and Sides Painted with Zolatone Finish (Light Gray)	■	■	■
Painted Exterior	White Standard	■	■	■
Cot Mounting System	Styker Cot Mounting System	■	■	■
Dome Lights	Two (2) 14" Fluorescent Light Fixtures	■	■	■
Grab Handles	Two (2) Interior Vinyl Coated Handles	■	■	■
Windows	Two (2) Sliding/Tinted/Auto Safety Glass	■	■	■
OPTIONS - CHASSIS AND CAB				
A/C Heater - Generator	Dometic 13.5 K A/C Heater - Onan 2800 KW Generator	N/A	□	■
Backup Alarm	87DB Back up Alarm	□	■	■
Cab - w/ Windshield and Steel Doors	FOPS/ROPS Certified Steel Cab with Steel Doors	□	□	■
Cab - w/ Windshield and Vinyl Soft Side Doors	FOPS/ROPS Certified Steel Cab with Vinyl Doors	□	■	□
Deep Cycle Battery, On Board Charger, Auto Eject Shoreline	Group 27 Battery with Auto Eject Shoreline	□	□	□
Deep Cycle Battery, On Board Charger, Manual Shoreline	Group 27 Battery with Manual Shoreline	□	■	■
Fire Extinguisher – 2 lb ABC (Max 2)	Two (2) 2lb 5BC	□	□	□
Generator Door - Custom Lettering (Aluminum Skirting Required)	Custom Department ID Lettering - 4 Max	□	□	□
Generator Only Package (Deep Cycle Battery Package Required)	Onan 2800 Watt Microlite	□	□	N/A
Generator Voltage - 220 System Upgrade	220 Volt System	□	□	□
Guard - Brush	Painted Black Steel	□	□	□
Guard - Brush Guard Extension	Painted Black Steel	□	□	□
Guard - Headlight Guard	Painted Black Steel	□	□	□
Heat Control Package - Cab/Engine (Cab Required)	POLYDAMP® Acoustical Foam Insulation	□	□	■
Paint - Hood, A/C Cover, & Black Dash	Customer Specified Color	□	□	■
Power Steering	Unisteer® Electrically Assisted Steering	□	□	■
Rear Hitch Receiver	2 in / 5.1 cm ASAP Custom Built	□	□	□
Roof & Roll Bar	Polaris Roll Bar - .125" Thick Tread Plate Roof	■	N/A	N/A
SCBA Seat Back – Driver and Passenger (Cab Required)	Accommodates SCBA Back Pack Bottles	□	□	□
Siren and Speaker	MS 4000 Siren / MS 100-01 Speaker	□	□	■
Skirting - ABS	.375" Thick ABS Side Skirting	■	N/A	N/A
Skirting - Aluminum Tread Plate w/ Step Bumper	.125" Thick Aluminum Treadplate Side Skirting	□	■	■
Steel Mesh Windshield (Roof & Roll Bar Required)	Woven .25" Diameter Steel Rod - 2" Grid Pattern	□	N/A	N/A
Step - Rear	40" x 10" Aluminum Tread Plate Step	■	N/A	N/A
Switch Panel - Four Position	Four (4) Rocker Switches with Backlight ID Tags	□	■	■
Tailpipe	1.5" Tailpipe - Extends to Rear of Vehicle	□	□	■
Underbody Storage Compartments (Aluminum Skirting Required)	24" W x 17" H x 17" D - .125" Thick Alluminum	□	□	■
Winch – Front 4500 LB	4500 lb / 2,045 kg	□	□	□
Winch - Multi 4500 LB	4500 lb / 2,045 kg Portable	□	□	□
Windshield Wiper – Passenger (Cab Required)	Polaris Standard	□	□	□
OPTIONS - PATIENT COMPARTMENT				
ALS Cabinets Package – Lower Cabinet Only	ASAP Custom Lower Cabinet	□	□	□
ALS Cabinets Package – Overhead Cabinet Only	ASAP Custom Upper Cabinet	□	□	□
ALS Cabinets Package – Upper & Lower Cabinets	ASAP Custom Upper and Lower Cabinets	□	□	■
Awning Package – 6' x 4'	CareFree Awning 72x48 in / 182.9x121.9 cm	□	□	□
Backboard Mounting Brackets (60" Bench Seat Required)	Three (3) T Shaped Brackets	□	□	■
Bench Seat – 30" w/ Seat Belt, Seat Pad, Built in Storage	30" Bench Seat with Durawear® Covered Seat Pad	■	N/A	N/A
Bench Seat – 60" w/ Seat Belts, Seat Pads, Built in Storage	60" Bench Seat with Durawear® Covered Seat Pads	□	■	■
Bench Seat – Back Pads - 60" (Wall Mounted)	Durawear® Covered Dual Back Pads	□	□	□
Door - Rear Canvas	Canvas Roll up Door with Dual Side Zippers	■	N/A	N/A
Door - Rear Hinged Double	ASAP Double Hinged Aluminum Doors	□	□	□
Door - Rear Rollup	Aluminum Extruded Shutter Style Door w/Lexan Window Slots	□	■	■
Door - Side Access To Bench Storage	Bottom Hinged 48" W x 13 3/4" H	□	□	■
Grab Handles	Two (2) 30" Exterior Aluminum	□	■	■
Insulation - Vinyl Covered Headliner Panel	Vinyl Covered Headliner Panel	□	■	■
Insulation - Vinyl Covered Interior Wall Panels	Vinyl Covered Side Wall Panels	□	■	■
IV Holder	One (1)- Rubber Style	□	■	■
Outlet - 110 Volt (Generator Package Required)	110 Volt Outlet - Dual Plug	□	□	□
Outlet - 12 Volt	Single 12 Volt Outlet	□	■	■
Paint – Two Tone or Custom Paint Color	Customer Specified Colors	□	□	□
OPTIONS - LIGHTING				
Front Scene/Work Lights (2) (Deep Cycle Battery Required)	Two (2) - Hella Module 70 Sealed Beam	□	□	□
Rear Scene/Load Light	One (1) - Hella Module 70 Sealed Beam	□	■	■
Side Scene Lights	Two (2) - Whelen 700 Series Light with 15° Down Bezel	□	□	□
Telescoping Light – 500 Watt (Generator Required)	500 Watt Telescoping Lights	□	□	□
Turn Signals	Four (4) lights- Two (2) yellow in Hood/ Two (2) Red in Tail Panel	□	■	■
Whelen 30" Dominator Super LED Light Bar	30" Light Bar Eight (8) TIR3: Six (6) Red , Two (2) White	□	□	■
Whelen TIR3 LED Emergency Lights – Four (4)	Four (4) TIR3 Light Heads	□	■	■
OPTIONS - TIRES				
Carlisle AT 489 Off-Road Tires - 6 Tires	Carlisle ATV 489 Tires	■	■	□
Carlisle All-Trail/Turf Tires - 6 Tires	Carlisle All Trail Tires	□	□	■
Spare Front & Rear Tire with Wheels	One Front and One Rear Mounted Tire	□	□	□
Tire Balls Run Flat System – 6 Tires	TireBalls® Run Flat Systems	□	□	□
OPTIONS - WHEELS				
Aluminum Wheels – 6 Wheels	Vision - Bruiser Aluminum Wheels	□	□	■
Steel Wheels - Painted Black	Polaris - Black Steel Wheels	■	■	□

■ Denotes Standard For Model
□ Denotes Available Options

MEDSTAT STANDARD SPECIFICATIONS

DIMENSIONS

Length	168 in / 426.7 cm
Width	63 in / 160 cm
Height	93 in / 236.2 cm
Wheelbase	102 in / 259.1 cm
Ground Clearance	9 in / 22.9 cm
Dry Weight	2950 lbs / 1338.1 kg
Turning Radius	186 in / 472.4 cm

INSTRUMENTATION / FEATURES

High Beam Indicator	Standard
Gear Indicator	Standard
Digital Fuel Gauge	Standard
Warning Light	Standard
Water Fording	30 in / 76.2 cm

FUEL

Fuel Tank	9 GAL / 34.1 L
Type Fuel	Gas 87 Octane or 89 Oxygenated

CAPACITIES

Patient Compartment	59x85x58in / 149.9x215.9x149.9 cm
Vehicle Payload	850 lbs / 386.4 kg
Towing Capacity	1750 lbs / 793.8 kg
Hitch Tongue Weight	150 lbs / 68.1 kg

ENGINE

Engine Type	Twin cylinder, 4 StrokeT 683 cc/ 40HP
-------------	---------------------------------------

DRIVETRAIN

Transmission	Automatic
--------------	-----------

MEDSTAT TESTING RESULTS

Transportation Research Center East Liberty, OH

Tested February 8, 2006

Tilt Table

Left	24.2°
Right	27.0°

Braking

	10 mph	17 mph
Skid Pad	4.4 feet	14.8 feet
Gravel	5.8 feet	16.3 feet

Slope Climbing

		Forward	Reverse	Stop, Shut down, Descend
40%	21.8°	Yes	Yes	Yes
50%	26.6°	Yes	Yes	Yes
60%	31.0°	Yes	Yes	Yes

Tractive Effort Pulled Pick-up Truck through soft sand

Off-Road Tire EMT Mud Runner	Passed
------------------------------	--------

AIR CONDITIONING TESTING

Dometic Environmental Chamber La Grange, IN

Tested July 28, 2008

Chamber Temperature 110°F

Maintained Overnight

Cooling

Time	Cab	Patient Compartment
Beg. Temp	110.6°	111.58°
1 Hour	110.6°	84.38°
2 hours	82.6°	79.90°
3 Hours	81.3°	79.30°
4 hours	78.6°	78.60°

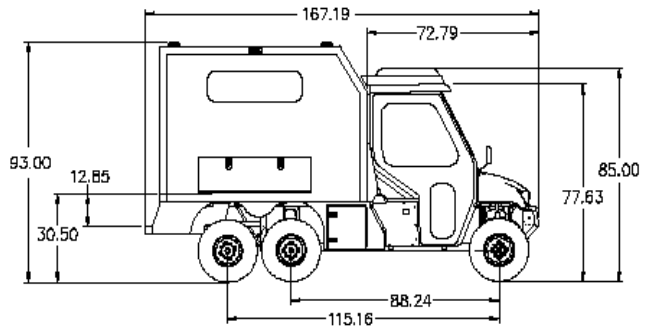
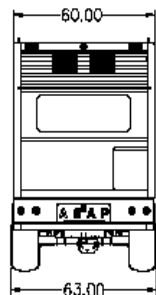
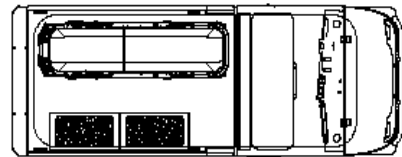
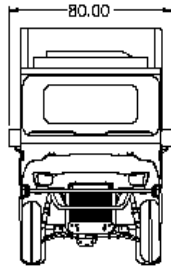

For more information, please visit the ASAP website, www.ASAP911.com
Contact us at: mnatoli@asap911.com or Call 1-877-929-2727

