



STANDARD FEATURES AND OPTIONS SPECIFICATIONS

STANDARD FEATURES - CHASSIS	SPECIFICATIONS	
Polaris Ranger 6 x 6 Chassis - Modified	On Demand Six Wheel Drive 40 HP, Up to 40 MPH	■
Power Steering	Unisteer® Electrically Assisted Steering	■
Roof & Roll Bar	Polaris Roll Bar - .125" Thick Tread Plate Roof	■
Headlights	Two (2) 50 Watt Quartz/Halogen Bulbs	■
Water Tank	Polypropylene Tank holds 150 Gal. of Water / 12 Gals. Of Foam	■
Hose Reel	Manual Reel with Capacity of 100' of 1" Booster Hose	■
Fire Pump- Darley Davey 13HP	Darley Davey 120 GPM at 40 PSI / 60 GPM at 133 PSI	■
OPTIONS - CHASSIS AND CAB		
Backup Alarm	87 DB Back up Alarm	□
Cab - w/ Windshield and Steel Doors	FOPS/ROPS Certified Steel Cab with Steel Doors	□
Cab - w/ Windshield and Vinyl Soft Side Doors	FOPS/ROPS Certified Steel Cab with Vinyl Doors	□
Deep Cycle Battery, On Board Charger, Auto Eject Shoreline	Group 27 Battery with Auto Eject Shoreline	□
Deep Cycle Battery, On Board Charger, Manual Shoreline	Group 27 Battery with Manual Shoreline	□
Guard - Brush	Painted Black Steel	□
Guard - Brush Guard Extension	Painted Black Steel	□
Guard - Headlight Guard	Painted Black Steel	□
Mirrors	Left / Right / Rear View	□
Rear Hitch Receiver	2 in / 5.1 cm ASAP Custom Built	□
SCBA Seat Back – Driver and Passenger (Cab Required)	Accommodates SCBA Back Pack Bottles	□
Siren and Speaker	MS 4000 Siren / MS 100-01 Speaker	□
Skirting - ABS	.375" Thick ABS Side Skirting	□
Steel Mesh Windshield (Roof & Roll Bar Required)	Woven .25" Diameter Steel Rod - 2" Grid Pattern	□
Rear Fold Down Step- Two (2)	7" x 7" Galvanized Aluminum	□
Switch Panel - Four Position	Four (4) Rocker Switches with Backlight ID Tags	□
Tailpipe	1.5" Tailpipe - Extends to Rear of Vehicle	□
Turn Signals	Four (4) lights- Two (2) yellow in Hood/ Two (2) Red in Tail Panel	□
Winch – Front 4500 LB	4500 lb / 2,045 kg	□
Winch - Multi 4500 LB	4500 lb / 2,045 kg Portable winch	□
Windshield Wiper – Passenger (Cab Required)	Polaris Standard	□
OPTIONS - LIGHTING		
Fluorescent Dome Light	14" Fluorescent Light Fixture	□
Front Scene/Work Lights (2) (Deep Cycle Battery Required)	Two (2) - Hella Module 70 Sealed Beam	□
Rear Scene/Load Light (Deep Cycle Battery Required)	One (1) - Hella Module 70 Sealed Beam	□
Side Scene Lights (Deep Cycle Battery Required)	Two (2)- Whelen 700 Series Light with 15° Down Bezel	□
Whelen 30° Dominator Super LED Light Bar	30" Light Bar Eight (8) TIR3: Six (6) Red , Two (2) White	□
Whelen TIR3 LED Emergency Lights – Four (4)	Four (4) TIR3 Light Heads	□
OPTIONS - TIRES		
Spare Front & Rear Tires with Wheels	One Front and One Rear Mounted Tire	□
Carlisle All-Trail/Turf Tires - 6 Tires	Carlisle All Trail Tires	□
Tire Balls Run Flat System – 6 Tires	TireBalls® Run Flat Systems	□
OPTIONS - WHEELS		
Aluminum Wheels – 6 Wheels	Vision - Bruiser Aluminum Wheels	□
OPTIONS - PUMPS		
Hale 11HP Fire Pump	Hale High Pressure 110 GPM at 50 PSI / 50 GPM at 150 PSI	□
Hale 18HP Fire Pump	Hale High Pressure 135 GPM at 50 PSI / 105 GPM at 150 PSI	□
OPTIONS - PUMP COMPARTMENT		
Hose Reel - Electric	Capable of Holding 100' of 1" Booster Hose	□
Tool Box	21" W x 87"L x 10.5" H Constructed of Aluminum Tread Plate	□

■ Denotes Standard For Model

□ Denotes Available Options

WILDFIRE CHASSIS SPECIFICATIONS

DIMENSIONS

Length	160 in / 406.7 cm
Width	63 in / 160 cm
Height	74 in / 188 cm
Wheelbase	102 in / 259.1 cm
Ground Clearance	10 in / 25.4 cm
Dry Weight	2510 lbs / 1338.1 kg
Wet Weight	3760 lbs / 1705.5 kg
Turning Radius	186 in / 472.4 cm

INSTRUMENTATION / FEATURES

Speedometer	Standard
High Beam Indicator	Standard
Gear Indicator	Standard
Digital Fuel Gauge	Standard
Warning Light	Standard
DC Outlet	Standard 2 Outlets
Top Speed	42 MPH / 67.6 KPH
Water Fording	30 in / 76.2 cm

DRIVETRAIN

Transmission	Automatic
--------------	-----------

FUEL

Fuel Tank	9 GAL / 34.1 L
Type Fuel	Gas 87 Octane or 89 Oxygenated

ENGINE

Engine Type	Twin cylinder, 4 StrokeT 683 cc/ 40 HP
-------------	--

WILDFIRE TESTING RESULTS

Transportation Research Center East Liberty, OH

Tested September 8-9, 2008

Tilt Table

Left	30.7°
Right	34.4°

Braking

	20 mph	30 mph
Skid Pad	25.1 feet	47.1 feet
Gravel	23.2 feet	58.2 feet

Slope Climbing

		Forward	Reverse	Stop, Shut down, Descend
40%	21.8°	Yes	Yes	Yes
50%	26.6°	Yes	Yes	Yes
60%	31.0°	Yes	Yes	Yes

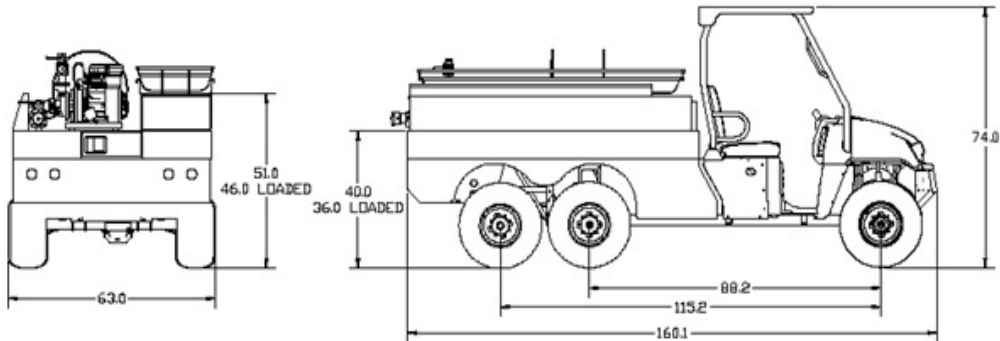
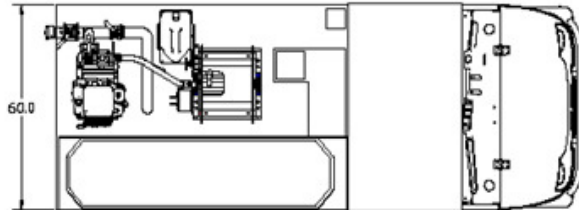

For more information, please visit the ASAP website, www.ASAP911.com,
Contact us at: mnatoli@asap911.com or Call, 1-877-929-2727

Rev 3/10/09